

**EUROPEAN FEDERATION**  
**of RADIO OPERATED**  
**MODEL**  
*Automobiles*



**APPENDIX 1**  
**HANDBOOK**  
**2013**

## APPENDIX 1

### 1/8th SCALE IGNITION TRACK CARS

#### 1. ALLOCATIONS FOR EUROPEAN CHAMPIONSHIPS

- 1.1. The allocations for the EFRA European Championships 1:8 scale will be established by the section meeting and published in the minutes.
- 1.2. For allocation and re-allocation procedures see 3.6. and 6.2.  
Allocations will only be offered for EC and WC events to those member countries that have written to request places.
- 1.3. All countries receive re-allocated places in the order of the Allocation-list, unless stated otherwise in this list.
- 1.4. The number of entries for EFRA European Championships is 120 with a maximum of 150. Accommodations for at least 120 drivers must be available.  
If the number of entries exceed 120, the accommodation must be sufficient for all participants.
- 1.5. Applications for all EC's must be done in writing by using the applications forms to be presented at the annual AGM section meeting

#### 2. RACING FORMAT EFRA EUROPEAN CHAMPIONSHIPS AND GRAND PRIX

- 2.1. European Championships are held in following classes:
  - a) The European Championship Sportscars/GT-P/Group-C will be held on the 4th weekend of July. In the year there is an IFMAR World Championship outside the EFRA bloc than dates between EC and WC must separated with at least 4 free weekends between the finals.  
In the years there is an IFMAR WC in the EFRA bloc there will be no EC-A (see schedule IFMAR, next WC 1:8 IC track will be 2009 and 2017)  
It will be open to EFRA "A" and "B" licensed drivers. EFRA "A" licensed drivers should have preference.  
One special EFRA medal will be awarded to the fastest driver under 17 year. So everybody of 16 years during the race dates, or younger can compete for this medal. One trophee must be awarded by the Organizer.
  - b) The B-European Championship will be held on the last weekend of May and will be open to:  
EFRA "B" licensed drivers 1:8 scale IC track.  
EFRA "B" licensed drivers 1:10 / 200 mm IC track.  
Not allowed to drive are furthermore: Top 10 from previous years EC 200 mm Electric, IC track 200 mm, Large scale, Off-Road 1:8 scale, Electric Off Road and EC-B.  
Participation in this event will not effect the ranking list. The winner of this championship will be EFRA "A" licensed immediately after this race. At this event the same body as the EC-A will be used.  
One special EFRA medal will be awarded to the fastest driver under 17 year. So everybody of 16 years during the race dates, or younger can compete for this medal. One trophee must be awarded by the Organizer
  - c) The EFRA ranking list is based on the last 2 EC 's, the last WC and the best result of one GP in the past year. An EC result is the result of the Sportscars/GT-P/Group-C EC from July. The total result of this list will decide upon A and B licence at the end of the season. For all the races involved in this ranking, points can be achieved for the result after the finals (see points table section 3.3.6) and 50 % of those points for the result after the qualifications. Both

results will be added together for the racing. During qualification A and B licensed drivers must be separated in different heats.

- d) European Championship 1:8 track 40+  
EC 40+: Open to all drivers of 40 years, including those who become 40 that year and older.
- e) European Championship 1:8 IC Flat Chassis. Open to all drivers with a valid EFRA Licence. Date to be proposed by 1:8 IC Track section.

The allocated dates of the A-drivers EC and that of the B-drivers Championship may be exchanged by simple majority vote at the AGM in the years that a World Championship is being held.

Allocations and reallocations procedure will be fixed at the AGM's section meeting. The format of EFRA GP's could be the same as for EC's but may be shortened up depending on the number of entrants.

- 2.2. Free practice for E.C. is only allowed from Monday preceding the Race. It will not be allowed to practice for participant's 10 days before this Monday (see also 8.1.). However pitlane refuelling may be forbidden during free practice at EC if it is necessary to facilitate a quicker turn-around of drivers (every five minutes).
- 2.3. Free practice for Grand Prix events must be allowed at least from Friday preceding the event (see 8.2.).
- 2.4. General Qualifying format for EC's and GP's: Minimum 4 and Maximum 6 series of 5 minutes heats depending on the number of drivers.
  - If there are 60 drivers or less, 6 rounds.
  - If there are >60- <80 drivers, 5 rounds.
  - If there are more than 80 drivers, 4 rounds

With everybody qualifying for Christmas tree sub finals and NO drivers qualifying directly for the main final. Depending on time available at Saturday all finals higher than 1/64th will be shorter than 20 minutes (for instance 10 minutes). See also 2.6

- 2.5. Time Schedule
  - The time schedule should not be rigid but adapted to the number of entrants. As a guideline at EC's with 120 or more entrants the schedule should be as follows;
  - Monday - Wednesday: free or controlled practice
  - Wednesday & Thursday: technical inspection
  - Thursday: controlled practice and 1st series of qualifying in the afternoon.
  - Friday: Round 2 till 4, lower finals till 1/64.
  - Saturday: 1/32 upwards, 1/16th, 1/8, 1/4 final; 1/2 final, final.

The heats shall contain a maximum of 10 drivers. These practice heats will be of 10 minutes of duration. The schedule of all practice heats including each practice heat starting time will be carried out by the organisation of the event and it should be given to the Team Managers & published for general knowledge.

- 2.6. General sub-finals and final formats for EC and GP: the sub-finals are 20 minutes up till 1/64 finals. Time for all finals higher than 1/64th to be set at team managers meeting. The duration of the final is 45 minutes.
  - Sub-finals: The best 3 of each sub-final move up to the next final.
  - Semi-finals, the best 4 of each semi-final move up to the main final, plus the best 2 remaining drivers from the 2 semi-finals combined.
  - When racing conditions are wet in the 2 semi-finals, the best 5 of each semi-final move up to the final. Starting order for the drivers who moved up to the final is based on number of laps and time. In different circumstances it will be number 1 from the A-final who gets the number 1 and the number 1 from the B-final who

gets the number 2 etc. Sub-final B even is the first final to start on the Saturday afternoon.

After the first semi final all cars will be put in Parc Fermé in technical inspection and they will be released after completion of the technical inspection of the 2nd semi final. This will give all drivers that proceed to the final equal time for preparation.

2.7 Frequencies for semi-finals and finals are not published and must remain secret. The Race Director will allocate frequencies to the drivers personally after they have proposed to him 2 or 3 different frequencies. A radio check must be made before the start of the final.

2.8 During the race 2 (two) mechanics are allowed in the pitlane.

2.9 A ranking system will be made based on the GP results, 2 worst results can be taken out, to define a Pro-Open ranking. This is no official EC series, but will be called, Pro-Open "year".

### 3. TRACK SPECIFICATIONS

3.1. Track surface should be unsealed asphalt or coarse finish with any joints smoothed.

3.2. Minimum length must be 200 metres ( advised 240-300 mtr. ).

3.3. Minimum width of the track will be 4 mtr. between marking lines. The maximum width is 6.50 mtr.

The marking lines must be 8-10 cm wide and either white or yellow. They must be approximately 20 cm away from the edge of the racing surface.

3.4. Maximum distance from the middle of the drivers rostrum to the furthestmost point of the track must be 60 metres.

3.5. Vision: no obstacles may interrupt the vision from the drivers rostrum to any part of the track.

3.6. A broken line may be drawn in the middle of the straight to aid vision. No lines may be drawn in corners other than the marking line.

3.7. The refuelling and pit area should be clearly distinguishable from the main track and as close as possible to the drivers rostrum. Exit from and entrance to the main track is advised to be on a slow part of the track.

3.8. Track design must include both right and left hand turns and must have a straight of minimum length 45 metres.

3.9. Outside barriers must provide a positive means of stopping a car which misses a corner or runs out of control. The primary consideration for selection of the outside barriers shall be the protection of the spectators and not the cars.

3.10. Inside barriers must deter corner-cutting and prevent cars reaching other parts of the track. Inside barriers must be positioned and dimensioned to prevent cars from flying over the outside barrier into the public enclosures.

The barriers must be smooth. When cones or dots are used, they should not be higher than 5 cm.

3.11. Barriers must be a minimum of 20 cm. away from the marking lines on the track.

3.12. The inner and outer surrounds to the track must be of grass or other suitable materials such as concrete. The object of these surrounds is to slow down any car that leaves the racing surface. The car must be able to leave the infield or outfield on their own to minimise the need for Marshall's assistance.

3.13. A start/finish line must be painted across the track, preferably in front of the time keeping position.

The first start line box must be located more than 10 mtr. away from the following corner.

3.14. Only a Le Mans type of start will be used. For Le Mans type of starts, 10 numbered boxes will be located on the edge of the track, at an angle of 20-45 degrees to

the track, minimum 5 mtr. apart. The boxes must be 70-100 cm long and 30-40 cm wide.

- 3.15. Race Directors must use the staggered starting system (see general rules 9.).
- 3.16. Race Directors and referees involved in EFRA sanctioned events may be invited to a briefing meeting covering interpretation of the rules and management of international races, so that they feel confident to manage a good race.

**4. RACE PROCEDURES 1:8**

(see also General Race Procedures Chapter 8). The arrangements of the heats and the numbering will be defined with the best result of 3 consecutive laps of the Driver, made during 2 controlled practice runs with the A-drivers still running in the last 3 heats.

The drivers must stand adjacent to their numbers on the rostrum; the mechanics must remain in their boxes along the pit lane.

For all finals, drivers with the lowest starting numbers may choose their position on the rostrum and the mechanics must stand under the driver where this is possible.

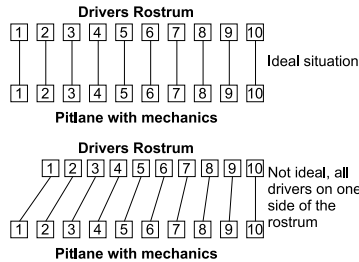

- 1 There must be a 3 min. gap between the end of one heat and the start of the next heat.  
Also a minimum of 2 minutes must be allowed between the issuance of the transmitters and the start of the heat.
- 2 An audible warning will be given at 1 minute and again at 30 seconds prior to the official start, in English and other languages as appropriate.
- 3 From 30 seconds till 3 seconds the cars must be hold at the starting boxes. If a car is not at the starting box at 3 seconds due to unforeseen problems the car may start from the pitlane after other cars have officially started. The race director and referees will monitor for the abuse of this facility.
- 4 For all finals, from 10 seconds until 3 seconds prior to the start a second by second count-down will be made in English.
- 5 In case of LeMans Grid Starts at 5 seconds prior to the start, the Starter will lower the starting flag and at 3 seconds the flag will be fully down. At this point, all cars must be released by the mechanics, who will all step back 1 meter.  
The cars must remain in the boxes, no part of the car touching the starting line.
- 6 From 3 seconds the verbal count down stops and the actual start-signal will be given by the Starter after a period of between 0 and 5 seconds has elapsed.  
If the grid is not to the satisfaction of the Starter, he may require a re-start, re-commencing the count down from 30 seconds.

- 7 The official start signal will be audible by means of a hooter, operated by the Starter.  
This signal will also start the Timing Systems.
- 8 Early starts, (i.e. any part of the car touching the starting line) will be penalised with a "STOP and GO" penalty. The time for this "STOP and GO" has to be set at the team managers meeting before the actual race starts and will have a maximum of 10 seconds.  
This penalty is issued by the Starting Official, Race Director or the Referee and must be announced immediately after the start. The penalty will be marked on the result-sheet.
- 9 Under no circumstances will the race be stopped due to a jump start.
- 10 The Starter may only interrupt the race and make a re-start in the event that he considers the starting procedure or the start was not carried out correctly.
- 11 Delayed start.  
As long as the starter has not called 30 seconds (the trial lap, see 4.3 is part of the procedure after 30 seconds) the cars to the start line, any participant of the semi-finals and final may request a delay of 10 minutes to carry out repairs on his car. This delay can be granted only once for each semi final and the final.
  - the track is closed, if the delay is requested as a result of frequency or radio problems
  - the track is open, if the delay is requested for mechanical repairs or problems.

Any driver asking for a delay will start from the end of the grid (11th position to be painted on the track) or from the pitlane in case he is not in time at the grid.

#### 4.2. STARTING PROCEDURE OF HEATS

Starting for qualifying heats will be from the start line using staggered start - one by one in the following order:-

Round 1 1,2,3,4,5,6,7,8,9,10

Round 2 4,5,6,7,8,9,10,1,2,3

Round 3 7,8,9,10,1,2,3,4,5,6

Round 4 10,9,8,7,6,5,4,3,2,1

Round 5 5,4,3,2,1,10,9,8,7,6

Round 6 8,7,6,5,4,3,2,1,10,9

- 4.3. Starting for Sub Finals and Final will be on a "Le Mans" type grid depending on the track layout, with the faster Qualifier starting in front of the slower. During sub finals and final, a trial lap is driven to avoid frequency problems and to check the transponders. Cars will be released one by one by the starter.

- 4.4. -1 All Qualifying runs and finals are ran by "time plus next-lap" system. Qualifying heats are 5 minutes duration. Lower finals and semifinals 20 minutes and final 45 minutes.
- 2 When the time is over, an audible signal is given. A car finishes when it passes the finish line after the finish-signal is given. The car must immediately return to the pits and may not hinder other cars still racing.
- 3 In case of doubt (on the finish-line when time is over), a car may race one more lap and finish. Whether he finishes or not when time was completed, is up to the Time-keepers and cannot be disputed.
- 4 After returning to the pits, the engine must be stopped immediately and the transmitter turned off and impounded.

**4.5. Qualification Order and Finals.**

- 1 After all series have been completed the Qualification order is established, by taking the best result of each driver.
- 2 In case of more than one driver recording identical best results of qualifications the next best result is taken
- 3 In the case of more than one driver recording identical results in a final, the driver starting with the higher start number is classified as the faster, e.g. if number 5 and 2 have equal times, 5 is deemed to have higher final placing.
- 4 The sub-finals and final are run according to the schedule printed in the official race program, which may only be changed by team managers majority vote.
- 5 After all sub-finals and final are completed a final result list is prepared based on laps and time, bearing in mind the sub final order. In case of rain see 4.6.

**4.6. RAIN SITUATION**

In case of different weather conditions during subfinals the final classification will be as follows: Place 4 of subfinal A and Place 4 of subfinal B will both be awarded place 11th equal in the general classification.

Place 5 of subfinal A and place 5 of subfinal B will both be awarded place 13th equal in the general classification ..... and so on.

**4.7. RACE INTERRUPTIONS**

- 1 In the case of a race which is interrupted for more than 60 minutes for reasons beyond the control of the organisers (bad weather conditions with safety risks for all persons at the meeting), the referees together with the Race-director will decide whether to cancel or continue the meeting.
- 2 In the case of an interruption of a heat the entire heat will be re-run.
- 3 In the case of an interruption of sub-final or a final the following procedure will be used:
  - A. If less than 10 minutes of a final has been run, the results will be cancelled and a new start given for the total time of the final. Vehicles may be repaired before the new start.
  - B. If more than 10 minutes of the final have been run, the results at the moment of the interruption will be kept. The new start will be given for the time which remains to complete the final. Vehicles may not be repaired before the new start. The two results will be added to give the final and definitive placing. If the second start cannot be made for any reason, the results from the first part will be used as the final and definitive placing.
  - C. When the interruption takes place after 75% or more of the race is past, the results as at the time of the interruption becomes the final result.

At the moment of the interruption of the race, the drivers will leave their vehicles on the start-line under the control of the Race Director. They may switch off the radio and stop the engine. There will be no repairs carried out to the vehicle or changing of tyres. Any driver who does not observe this rule will be immediately disqualified.

**4.8. RAIN PROCEDURE DURING QUALIFYING**

- 1 The Race Director and the Referees are jointly responsible for the decision to stop a race in the event of rain.
- 2 On the result sheets the Race Director or the appointed official must mark a heat "WET" when the heat was raced under wet conditions. On the corresponding record sheets, this must also be marked.

The Race Director together with the Referees will decide in case of doubt. Heats are generally considered to be 'WET' when there is any rain or moisture on the track and it is obvious to the race director that the cars cannot perform to their maximum capability. The race director may decide to postpone qualifying if it is likely that qualifying can be resumed within reasonable time.

- 3 When all drivers have had at least one dry heat, all results will be counted.
- 4 When weather and time permits, the Race Director may decide to offer an extra heat to those drivers who did not have a chance to drive a heat dry (i.e. when most drivers had 2 resp. 3 dry runs, a 2nd. resp. 3rd. run may be offered to those who had only 1 resp. 2 dry runs).
- 5 When not all drivers have had a chance to run a dry heat, only the wet results will be counted.
- 6 When continuation is judged to be senseless, or when other drivers should be offered a fair chance to drive under dry conditions, the Race Director together with the Referees may decide to end a heat or cancel a complete heat (4.8.1.)
- 7 When all drivers have had at least 1 dry heat, the race-director will postpone the qualifying until the track is declared fully dry again. If it is likely that this will interrupt the qualifying for more than 1 hour, the race director may decide to open up the track for controlled practice
- 8 The use of a personal transponder is mandatory.

**5. TECHNICAL SPECIFICATIONS**

All measurements referred in this appendix are minimum or maximum values. All measurements for the motor dimensions to be considered with 2 digits behind the comma, all other measurements to be considered 1 digit behind the comma. Measurements must be within their maximum or minimum values under all Circumstances.

- 5.1. The engine may have a total capacity of not more than 3.50 ccm. A maximum carburettor diameter of 9.00 mm.
- 5.2. The fuel tank including filter and fuel pipes up to the carburettor may hold a maximum of 125.00 ml. No loose inserts allowed.  
Any tank found illegal (>125 ml) after a heat or final shall be removed from the car and inspected for a second time after an initial "cool down period" of approx. 15 minutes. This period of 15 minutes is only necessary in case the temperatures are above 20° C.
- 5.3. Overall dimensions of the car:  
Wheel base: 270.00-330.00 mm, overall width max 267.00mm  
Overall width of the body max.: 267.00 mm, measured on top of the wing and on top of the sides and the lower front side.  
The lower sides between the two front and rear wheel arches will not be taken into account for technical inspection as long as they are not wider as 277mm. If the body is wider as 277 mm on the lower sides the technical inspection has the right to take action with a first warning and when in second case with disqualification from the result. For all finals bodies must first pass technical inspection for verification and first warning is not applicable.
- 5.4. TYRES:  
Tyres must be black, except for writing on the side wall (exceptions only after EFRA agreement). Foam and/or rubber tyres can be used. Treatment of tyres with any type of additive is strictly not allowed.



A controlled tyre is mandatory for:- controlled practices (which are used for seeding), qualifying, and sub/finals (7 sets). Only organiser supplied controlled tyres can be used (Hand-Outs).

Definition of a controlled tyre: 1 brand, 1 diameter front, 1 diameter rear, 1 shore for front and 1 shore for rear.

Shore hardness for 1/8th: "32 front and 35 rear" (final number of shore after consultation with the organiser).

If the Hand-Out tyres have any visible defects (bad glueing, visible damage to tyre or rim) the effected tyre(s) can be exchanged before the race start by race control. Production tolerances (including shore hardness) will not be considered as a defect.

Tyres must be used as they are supplied (no modification to the rims, except the axle hole and no shore meters can be used to select tyres) and will be given out and fitted in the controlled area. Drivers must use new tyres every controlled practice, qualifying heat and sub/final.

Tyre dimensions for 1/8th. :

Maximum width of rear tyre: 64.0 mm.

Diameters -- 69.0 mm front, 76.0 mm rear.

Information about the tyre brand and shore must be available 8 weeks before the event

The drivers must pay a deposit for the mandatory 7 sets of the controlled tyre in advance to EFRA, at the latest 10 weeks before the event.

Additional tyres for drivers that 'move-up' (in sub-finals) and for the Final, must be purchased with cash at the trackside. Tyres for free practice can be purchased on site from Monday onwards.

For free practice, drivers have free choice of tyres used, but no treatment is allowed. From the start of controlled practice (used for seeding), drivers have to use the Hand-Out tyres.

Rain:- In case of rain (decided by the Race director after consultation with the Section Chairman), any alternative tyre can be used which has not been treated in any way, with the aim to get more or less traction.

EFRA will provide information about track preparation which will be mandatory for the event.

#### 5.5. RIMS

The rim must not exceed 54.00mm. An edge to reinforce the rim on the inside (carside) of 2.00 mm thickness and 3.00 mm height is allowed, flange diameter max. 60.00 mm. Any fixing bolts or other equipment installed in the wheel rims may not extend beyond the exterior of the wheel rim.

#### 5.6. All vehicles must be equipped with brakes and a clutch in such a manner, that the vehicle may be held stationary with the engine running.

#### 5.7. Each motor must be equipped with an exhaust system and inlet silencer to reduce the amount of noise.

In case of rain and on instruction of the Race Director drivers can use something else as an INS box.

EFRA's definition of a noise level is always final. In that case the INS box is not mandatory.

Only EFRA homologated 3-chamber mufflers are allowed on EFRA sanctioned events. The EFRA homologation number must be engraved on the sidewall of the muffler.

- Race directors have the right to measure on track side and take out cars that make too much noise.
- 5.8. The front of the vehicle must be equipped with a bumper in such a manner, that it will minimise an injury in the case of it enters into contact with other participants or members of the public.  
The bumper must be made from a flexible material with all corners and sharp edges rounded off. The contour of the bumper will follow the contour of the body with which it is being used.  
At no point may the bumper protrude more than 5.00 mm in front and 13.00 mm on the sides of the body.
- 5.9. If a rear bumper is fitted it must finish not more than 50.00 mm behind the rear axle.
- 5.10. The aerial must be made from a flexible material.
- 5.11. All EFRA sanctioned events will be raced with open/closed cockpit prototypes/ sportscars/ canam type/GT-P's/Group-C or similar cars.  
All lists of approved equipment, (ie. Bodies, mufflers and batteries) must be available on EFRA's webpage from the 1st of March every year. This is the finale lists for this year and no changes will be made before the next year. Equipment homologated during the year will not be put on the list until 1st of March next year.
- 5.12. The body must be made from a flexible material and be painted properly. When initially entered in a meeting the body must be neatly finished.
- 5.13. A realistic driver (minimum 3 colors) made to 1:8 scale must be fixed in the correct position in an open cock-pit cars. The windscreen and windows must be translucent (ie. Not completely painted in)
- 5.14. All bodies must have the front and rear wheel arches cut out if the original was so designed.
- 5.15. CUT OUTS
- the windscreen must not be cut out. One hole of max. 6.00 sq. cm for cooling is permitted
  - side windows and rear windscreen may be removed
- It is not allowed to bend windows to the outside
- all parts of the vehicle must be covered, except:
    - a) cooling head of engine
    - b) air filter
    - c) aerial (max. 10.00 mm)
    - d) outlet pipe of muffler
    - e) fuel filler cap
    - f) roll-over bar
- Only if these parts are extending the body. Cut outs for above mentioned parts are to have no more than 10.00 mm clearance.
- In addition to this, the following holes are allowed:
- g) for muffler outlet
  - h) for fuel filler cap (50.00 mm maximum, round, viewed from above and not combined with the hole from the roll-over bar, or oval 40 mm x 60 mm maximum and not combined with the hole for the roll-over bar)  
Note: Hole for roll-over bar and fuel filler gap may not be combined.  
This rules refers to the GT-P/Group-C body.  
In case of the Proto types or open cockpit cars a clearance of 10 mm around the fuel filler cap is allowed.
  - i) for radio switch (max. 10.00 mm)

- j) for glow plug (max. 20.00 mm)
- k) fuel mixture valve (max 15.00 mm)

5.16. Specific body attributes

- a) Group C: Cars eligible for this class are those that have been used under "Group C" rules in the FISA Sportscar World Championship.
- b) GT1/GT2-Cars: Cars eligible for this class are those that are or have been racing in FIA GT Class. This can be either GT1 or GT2 cars like McLaren F1, Porsche 968 GT1, Ferrari F40, Marcos etc.  
The cut-out of the body at the rear is free after the rear axle, but rear lights must be fitted if the original is equipped with these.
- c) GT-P cars, eligible for this class are those that are or have been racing in the FIA "GT-P" class (see Le Mans 1999), or the Petit Lemans Series in America.
- d) Proto type CAN-AM cars, eligible for this class are those that are or have been racing in any official championship.

Homologation procedure; For all types of cars, the body shape behind the rear axle is not subject to control.

The outer edge of the wheels must be covered at the centre of the axles viewed from the top. All bodies must be homologated by EFRA.

The homologation number of the body must be visible, during the painting it will be possible to maintain transparent or semi transparent the EFRA number.

5.17. Wings and Spoilers

Separate wings and spoilers are not allowed. Only a Gurney strip mounted on the rear of the body is allowed. The gurney should be not higher as 5mm with a 90 degrees angle. See drawing. Maximum height for the body, side and rear wing is 170mm with the chassis raised on 20 mm blocs. This maximum height with the Gurney strip is 180 mm on a 20 mm spacer. The maximum overhang is 100 mm measured from the rear axle centre point.

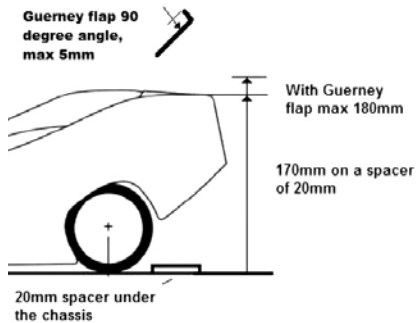

Maximum dimensions:

- 1) Group "C", GT-P, GT1 and GT2 cars
- max. width: 267 mm
- max. height: 170 mm (on 20 mm blocs)
- Overall, maximum height including a Gurney strip 180 mm.(on 20 mm blocs)
- max distance behind rear axle: 100.00 mm,
- 110 mm for 2wd & flat chassis cars

5.18. Checks at the technical inspection

- a) Before the race all cars will be checked and during the heats the following random checks will be made:
  - weight limit
  - muffler
  - body and spoiler

The chassis is to be indelibly marked before the race and if a driver wants to change it, he must present the new and the old to the inspection officer.

- b) During sub finals all cars moving up to the next final plus the next one are to be checked. In addition to the above mentioned checks the following are to be done during sub-finals:
- marking of chassis
  - fuel tank capacity
- c) The same checks must be made after the final for the top 4 places.
- 5.19. Fuel may only contain methanol (methyl alcohol) CAS number 67-56-1), lubricating oil, a small content of anti-corrosion chemicals and maximum 25% of nitro methane (Cas number 75-52-5) in volume. The specific gravity of the mixture may not be heavier than 0.91 grams/cc at 20°C and standard atmospheric pressure. For quick testing a Nitromax 25 can be used, but in case of failure with the nitromax an official density meter must be used to control the specific gravity of the fuel including the temperature recorded during the test. A specific table will be produced to report the density (gr/cc) based on the temperature (from 0 to 50°C) The tolerance on the measurement will be +/- 0,5% based on the data reported in density table.  
From 1st of January 2013 this specific gravity should not be more than 0.87 grams/cc with a maximum of 16% of nitro methane in volume. Any violation with fuel which means any proof of the use of other additives as mentioned will mean 5 years of disqualification from any EFRA and IFMAR event.
- 5.20. 4WD cars can be used without any technical restrictions except those listed in Section 5. The use of separate front wheel brakes, except through transmission is also not allowed (locking of one-way bearing is allowed).  
2WD cars are restricted to:
- Rear axle driven
  - Gearbox with maximum 2 gears
  - No front wheel brakes
  - No gas filled shock absorbers.
- Specifications of flat chassis cars:
- rear wheel propulsion only
  - one engine (one cylinder, 3.50 ccm air cooled)
  - brake on rear axle only
  - no gear box
  - no suspension, an articulated front end is allowed
- 5.21. The minimum weight limit of the cars:  
2400 grams for 4 WD cars, 2300 grams for 2 WD cars.  
The weight limit will be checked with the cars ready to race but with empty fuel tanks and with transponder. (personal or with battery)  
The weight will be checked on a digital scale balance and can be done before the start of the heat, sub-final, final or after the end of either.  
If the weight is found to be under the minimum weight the driver should be disqualified from the heat, subfinal or final.
- 5.22. The car shall be measured for width by placing it on a baseboard equipped with two side rails of 20 mm height spaced 267 mm apart, constructed in such a way, that the car can roll freely between them.  
Base-board and rails must be constructed of high quality board suitably stiffened to prevent distortion. The car must roll freely between the side rails with any steerable wheel set in the straight ahead position without any part of the wheels, bumpers, body shell or any other part of the car touching the side rails irrespective of the compression or extension of the suspension.

The car shall be measured for length and height in a similar constructed bow of internal dimensions 637 x 267 mm for Formula and Sports cars and 610 x 267 mm for GT cars which includes provision for checking the maximum height.

Measurement of the wheel base may be made by simple measurement of axle centre distance, but Race Directors should be prepared to make more exact checks in case of doubt or protests. It is suggested that the wheels are removed and the wheel spindles firmly placed on V-blocks whilst accurate measurements are made. It is the responsibility of the driver to ensure that his car complies with the regulation at all times, that it is on the track and the organiser may check any car for compliance with the regulations at any time during the race meeting.

If a car is found to exceed the limits of dimensions on checking immediately after a race, positive proof of race damage may prevent disqualification.

5.23 A roll bar may be fitted which must not project more than 30 mm above the cooling fins or roof, in case of, for instance a saloon car.

5.24 It is not allowed to use any electronic parts for "Traction Control and braking control (ABS)" which can control the power of the transmission by means of a feedback system.

It is not allowed to use any form of telemetry with active transmission.

5.25 All lists of approved equipment, (ie. Bodies, mufflers and batteries) must be available on EFRA's webpage from the 1st of March every year. This is the finale lists for this year and no changes will be made before the next year. Equipment homologized during the year will not be put on the list until 1st of March next year.

## **6. A & B LICENCE**

6.1. To qualify for an "A" licence, a driver must be placed 1-30 in the EFRA ranking system. All other applicants will be classified EFRA "B" licensed. These drivers must be approved by their own National Association as having sufficient experience and skill to take part in an International competition.

World Champion will retain "A" licence for the next 5 years.

European Champion will retain "A" licence for the next 4 years.

European Champion B-drivers will retain "A" licence for the next 3 years.

## **7. PENALTIES**

7.1. Referees must issue a verbal blue flag warning to slower drivers or to make drivers that are not within the same lap as the car that is about to pass him, to make way and not to obstruct the passing car. This warning must be announced "ATTENTION DRIVER (Name)"

7.2. Failure to respond to the verbal blue flag will result in an official warning and the driver must make a mandatory pit stop for 10 seconds. During this mandatory stop the Referee will administer the official warning directly to the driver. In the case that there is no possibility to call a driver for a stop and go penalty, the Referee and or Race Director will announce a time penalty of 10 seconds.

7.3. Any driver who is given 2 (two) official warnings will be immediately disqualified from the race in progress. After 3 (three) warnings the driver will be disqualified from the entire race.

7.4. Deliberate waiting for other cars will be treated as a verbal blue flag offence and a "Stop - Go" penalty issued. The Referee will advise the driver that his behaviour has been noted and that he should race normally. Failure to follow the Referees instructions will result in immediate disqualification. In the case that there is no possibility to call a driver for a stop and go penalty, the Referee and or Race Director will announce a time penalty of 10 seconds.

- 7.5 Deliberate obstruction of other cars in an attempt to influence the result of a race will lead to immediate disqualification and loss of his/her International Licence until after the next event of the same kind. (e.g. GP/EC/WC)